

# Eclipse RatioMatic

## Burners

Model RM1250

Version 5

Parameter	Specifications	
<b>Blower Type</b>	<b>Chamber Pressure "w.c. (mbar)</b>	<b>60 Hz Packaged Blower</b>
<b>Maximum Input, Btu/h (kW)<sup>1</sup></b> <i>For chamber pressures outside the given range or for varying chamber pressure conditions, contact Eclipse, Inc.</i>	-5.0 (-12.5)	14,600,000 (4279)
	-3.0 (-7.5)	13,800,000 (4045)
	-1.0 (-2.5)	12,900,000 (3781)
	0 (0.0)	12,500,000 (3664)
	1.0 (2.5)	12,000,000 (3517)
	2.0 (5.0)	11,500,000 (3371)
<b>Minimum Input, Btu/h (kW)<sup>2</sup></b> <i>For lower inputs, contact Eclipse, Inc.</i>	625,000 (183)	
<b>Maximum Chamber Temperature, °F (°C)</b>	Burner with alloy tube	1500°F (815°C)
	Burner with refractory block	1900°F (1038°C)
<b>Main Gas Inlet Pressure, "w.c. (mbar)<sup>3</sup></b> <i>Fuel pressure at ratio regulator inlet</i>	20 to 55 (50 to 138)	
<b>Pilot Gas Pressure at the Pilot Cock Inlet</b>	Minimum: 6" w.c. (15 mbar)	
<b>High Fire Visible Flame Length, inches (mm)</b> <i>Measured from the outlet end of the combustor</i>	144" (3.66 m) Measured from the end of the firing tube	
<b>Pilot</b>	Integral spark-ignited pilot	
<b>Flame Detection</b>	UV scanner only.	
<b>Fuels<sup>4</sup></b> <i>For any other mixed gas, contact Eclipse, Inc.</i>	Standard nozzles burn natural gas, propane, propane/air mixes without changing internals.	
<b>Blower Motor Power, Hp</b>	10.0	
<b>Weights, lbs (kg)<sup>5</sup></b>	Alloy Tube	807 (366)
	Refractory	1124 (510)
<b>Approvals</b>	 AM30	

<sup>1</sup> Maximum inputs for packaged blower versions are given for the standard combustion air blower without an inlet air filter.

<sup>2</sup> Turndown input based on neutral chamber conditions. Contact Eclipse for other chamber pressures.

<sup>3</sup> For proper performance, this pressure must be kept constant across the burner operating range.

<sup>4</sup> See Design Guide 110 for more information about typical fuel composition and properties.

<sup>5</sup> All weights are approximate.

- All information is based on laboratory testing. Different chamber conditions will affect the data.
- All inputs based upon gross calorific values and standard conditions; 1 atmosphere, 70°F (21°C).
- Eclipse reserves the right to change the construction and/or configuration of our products at any time without being obliged to adjust earlier supplies accordingly.

## Performance Graphs

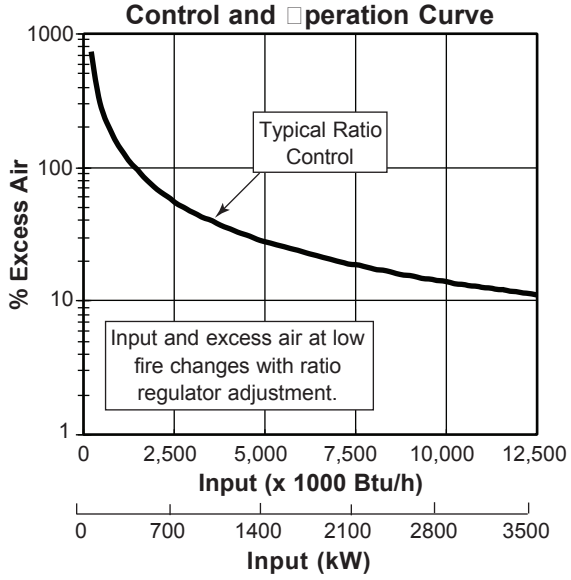

### Emissions from the burner are influenced by:

- Chamber conditions
- Fuel type
- Firing rate
- Ratio regulator adjustment
- Combustion air temperature

CO emission is largely influenced by chamber conditions. Contact your local Eclipse representative for an estimate of CO emission on your application.

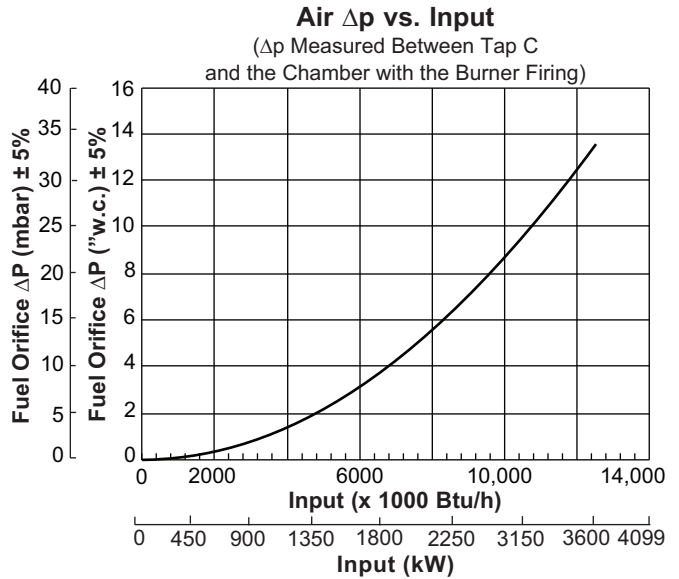
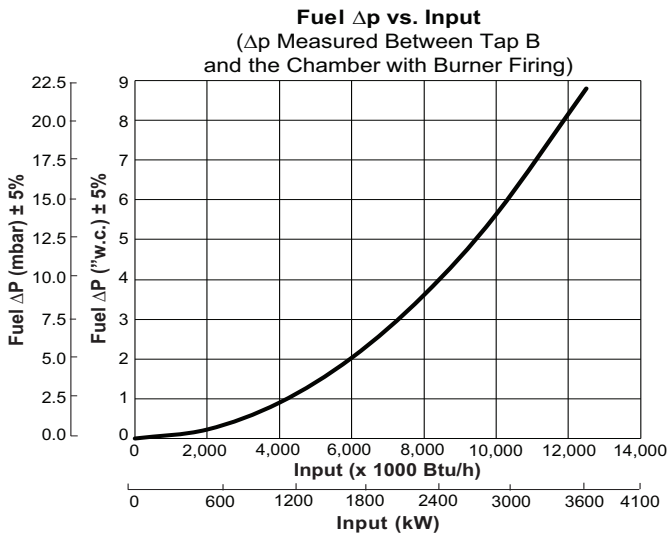

# Dimensions and Specifications

## Dimensions in mm (inches)

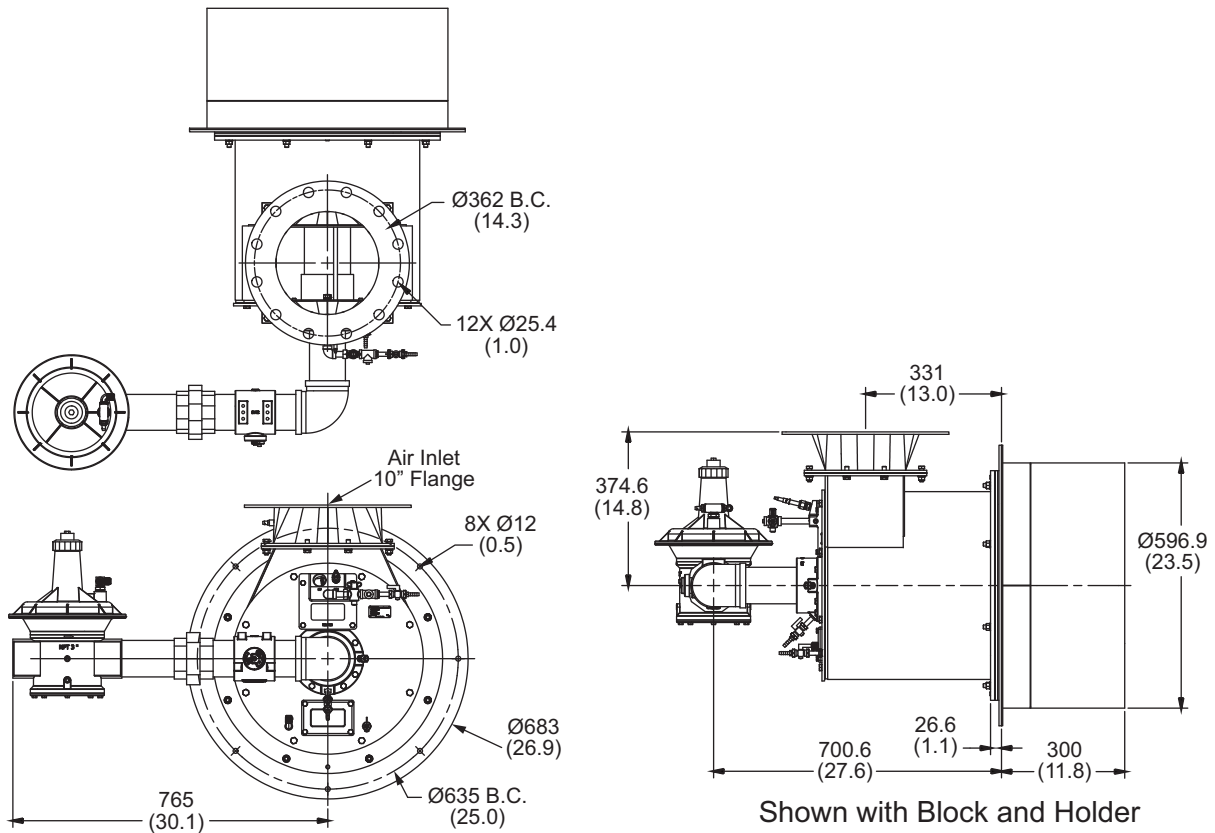
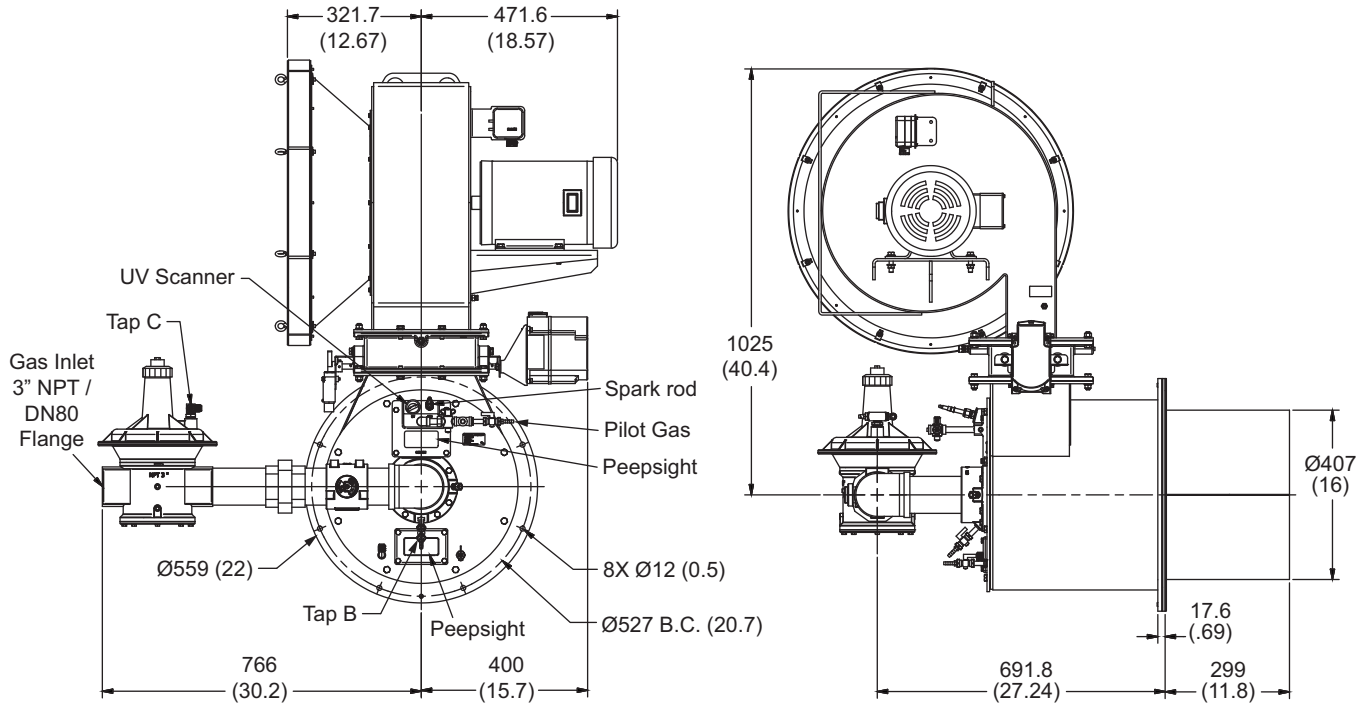

## Burner Configurations

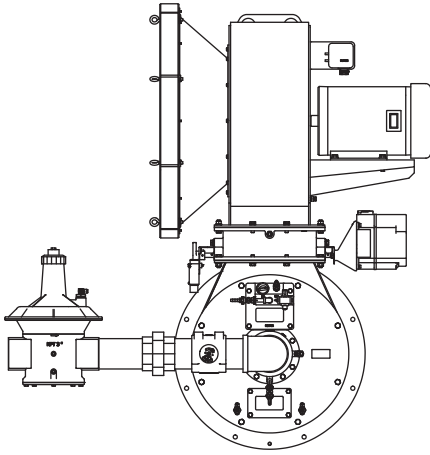

Left Hand Piping

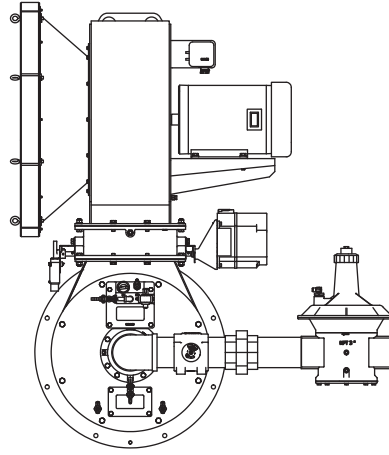

Right Hand Piping



### Offered By:

Power Equipment Company

2011 Williamsburg Road Richmond, Virginia 23231

Tel: 804-236-3800 Fax: 804-236-3882 [www.peconet.com](http://www.peconet.com)